

- NOTE
1. THIS DRAWING IS COPYRIGHT GSDA LTD.
 2. THE CONTRACTOR MUST NOT SCALE FROM THE DRAWING ALL DIMENSIONS TO BE TAKEN FROM DIMENSION STRINGS.
 3. WHERE ANY DISCREPANCIES ARE FOUND BETWEEN DIMENSIONS THESE MUST BE BROUGHT TO THE ATTENTION OF THE ARCHITECTS FOR RESOLUTION.
 4. WHERE DISCREPANCIES EXIST BETWEEN REFERENCE OR ASSEMBLY DRAWINGS & DETAIL DRAWINGS, THE LATTER TAKE PREFERENCE.

Key

Articulated Vehicle
(Inspection Bay Access)
Swept Path Analysis

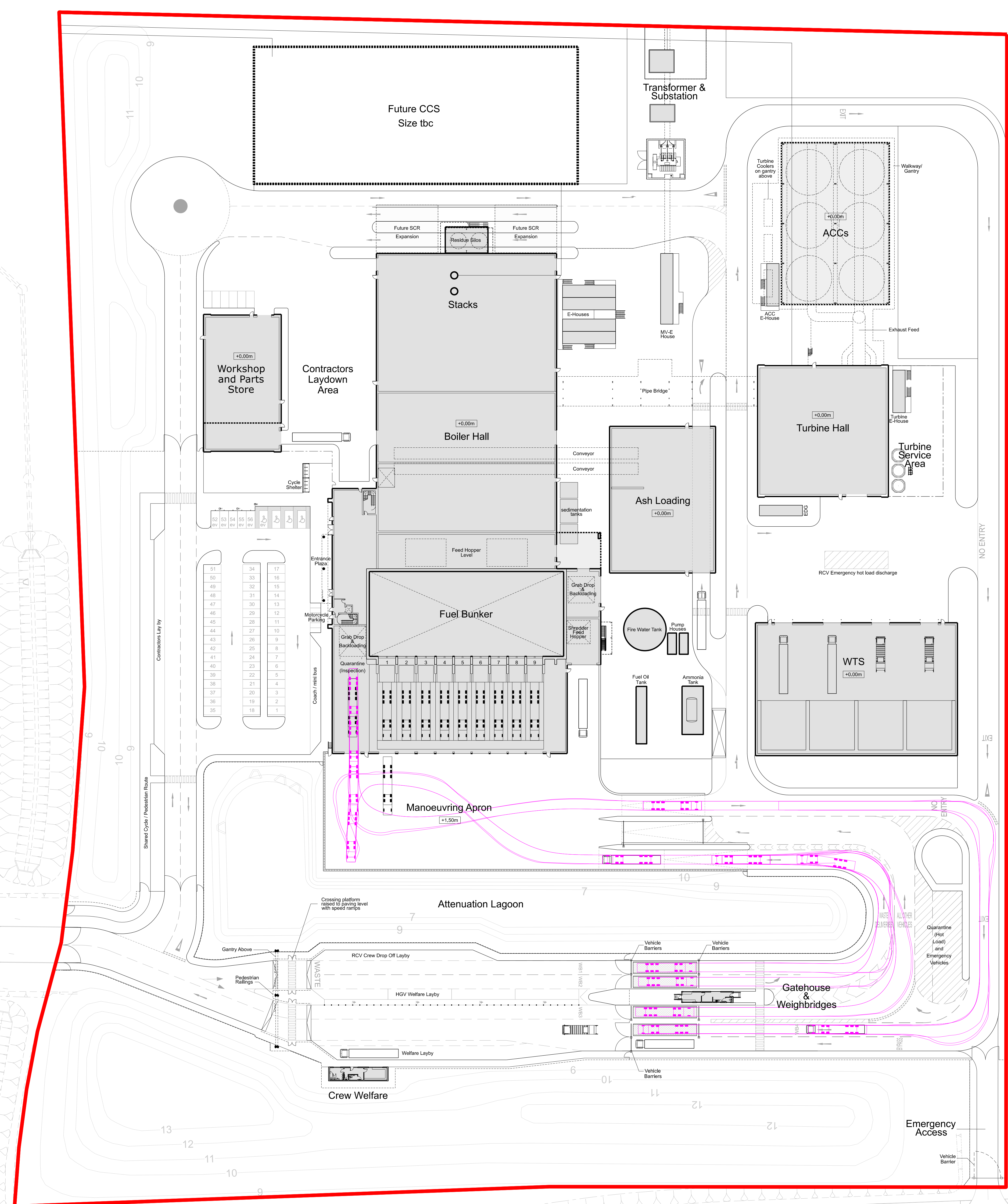
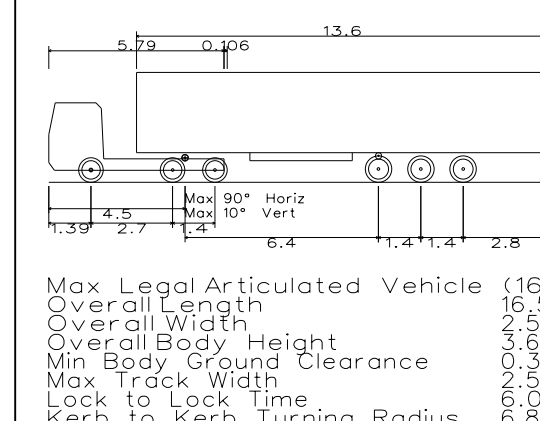

A	23/03/31	Issued for Discharge of Reserved Matters
A	22/02/28	Updated
-	21/11/23	Preliminary Issue

FOR PLANNING



01 Meadowlake Place, Thorpe Lea Rd, Egham, Surrey TW20 8HE, United Kingdom
T: 01932 629139

**Grangetown
Energy Recovery Facility**
PROJECT

Vehicle Swept Path Analysis,
Weighbridge to Inspection Bay
DRAWING

1:500@A0 23/03/31
SCALE DATE

1425_PL136 A

DWG. NO. REVISION CHECKED

